

Fostering Cognitive Development through the context of Mathematics: Results of the CAME Projectⁱ

Michael Shayer

King's College, University of London, 16 Fen End, Over, Cambridge CB4 5NE

Mundher Adhami

Kings' College, Department of Education, Franklin Wilkins Building,
Waterloo Road, LONDON, SE1 9NN

Abstract

The CAME project was inaugurated in 1993 as an intervention delivered in the context of mathematics with the intention of accelerating the cognitive development of students in the first two years of secondary education. This paper reports substantial post-test and long-term National exam effects of the intervention, yet, by discussing the methodology used, questions the assumptions implicit in the original intention. It is now suggested that a better view is to regard CAME as a constructive criticism of normal instructional teaching, with implications for the role of maths teachers and University staff in future professional development.

1. Introduction.

In this paper we present the findings of an intervention project on some 2500 11 to 13 year-olds which produced large (0.8 S.D.) long-term effects on the achievement of students when they reached the age of 16. Yet the methodology used is 30 years out-of-date and hence unfamiliar to many, believed by others to be permanently discredited, and is forgotten by some. It therefore seems necessary briefly to show the reasons for using it.

Suppose it were possible to estimate on a scale the difficulty of a piece of mathematics or a scientific concept. Suppose also that on the same scale it were possible to estimate the differential abilities of students. Would that not be delightful?—then one could match the learning presented to the ability of students to process it. Or, if a Vygotskian perspective is being taken (Shayer, 2003), one could judge just how far ahead of student's present ability to select their learning so as to promote their intellectual development.

During the 60s an approach was essayed on this task by behaviourists. Bloom's (1956) Taxonomy was to be the instrument for discussing the difficulty of learning. But how about a scale for estimating the

ability of students? Psychometric tests give a measure which has at least the virtues of being an interval scale, although even that has been contested (Embretson,1988). Yet as the art proceeded it narrowed its focus to comparing the abilities of children of the same age. Given a 10 year-old's standard score of 105 on a test of mathematics, what does that number tell you about what mathematics he should be able to process at age 14? What indeed does it tell you of what mathematics he can cope with at 10? All you know is that he is marginally above average for his age. It is worse still if the question is asked of a score of 135. Bloom's Taxonomy throws out a pier from one side, and psychometric tests throw out another from the other side, but without a theory of mathematical difficulty the chasm between yawns permanently unspanned.

By the Sixties also Piaget had brought to the threshold of adulthood his studies of the progressive psychological development of children. In what way might they do better than behaviourism and psychometrics?

Perhaps an analogy from Physics will help. Starting in the C17 there had been various measures of temperature, so by the C19 there were Reamur, Fahrenheit and Celsius scales, different numbers for the same thing. But it was only through a kinetic theory interpretation of temperature as molecular vibration that it was possible to conceive of an Absolute scale of temperature, and give its zero the meaning of no vibration.

In Piaget & Inhelder (1958) one is presented with a scale by which the level of different degrees of understanding of science concepts, and the intellectual level of the children working on them are described in one and the same terms. Thus in working on the Pendulum problem children at the mature concrete level (2B) can make observations based on simple causal thinking, and do find the effect of length. But because they confound the variables of weight and angle they only describe the phenomena. At the early formal level (3A) they have an idea about controlling variables, but may control the variable they are trying to test, and do not go further toward a solution. At the mature formal level (3B) they can find and prove that neither weight nor angle of swing affect the rate of swinging by designing and reasoning from controlled experimentation. *There* is an incipient Absolute scale of intellectual development that describes both the level of the task and the level of the learner. Piaget, (1953) worked on the bottom end of this scale back in 1929-31 by describing the development of his own children from two hours old up to 2 years of age. In measurement theory it took Rasch (1980) to show how the same principle of a common scale can be applied to the construction of tests (Wright& Stone, 1979).

Shayer & Adey (1981) by drawing widely on Piaget's work were able to produce a taxonomy by which every level of science curricula currently in use in schools could be assessed, and also produced tests which have been used ever since in schools, Piaget-based and Rasch-scaled, that are used to assess

the present level of students' understanding. This methodology is very convenient, and its re-consideration well overdue. Piaget's logic-based theory however, is admitted to be difficult, but recent neuro-psychological work suggests further use (Duncan, 2001).

1.1 Piaget's explanatory theory of cognitive development

Piaget's method for studying 'The psychology of intelligence' (his title, Piaget, 1950) was to go below the surface of all aspects of thought and describe the underlying logic involved in each thinking act: the argument being that, just as mathematical models are the essential language of physics, so too as 'logic is the mirror of thought' logical models serve an equivalent function for psychology (Piaget & Inhelder, 1958, p271).

Concrete operations

Dealing with the thinking of 5 to 10/11 year-olds logical operations of classification, ordering (seriation), transitivity, conservation of number (1:1 correspondence) and other conservations, causality, and aspects of number are described 'genetically' —that is, successive steps of mastery of these operations are reported experimentally, always embedded in real-world contexts. Viewed from the context of scientific and mathematical learning, the essential quality of 'concrete operations' is that they all *descriptive* models, that is, in their use they constitute more powerful eyes upon the world than simple perception of qualities, like 'red' 'three' 'heavy', 'big' &. But they do not carry the user below the surface of what is described: 'the longer the pendulum the slower it swings' is simply a more powerful way of summarising what is in common between several observations.

Formal operations

With some 12 to 16 year-olds a further stage of thinking is found. Piaget calls this 'reflective thought...when the subject becomes capable of reasoning in a hypothetical-deductive manner'. In the case of the Pendulum she sees that if she goes on varying both the weight and the length of the pendulum between experiments she is never going to know which affects the rate of swinging, or if both do. By comparing different controlled experiments she can then exclude any irrelevant variable, such as weight or angle of swing. So formal operations are a deeper operation of thinking on aspects of reality which first have been described using concrete operations. Piaget describes ten qualitatively different formal operations ('schemata'), but they are not exhaustive of reality.

Control of variables:

Investigation of many-variable problems-pendulum, flexibility of rods, many biological and social science problems

Exclusion of irrelevant variables

Combinatorial thinking

Notions of probability

Notions of correlation

Coordination of frames of reference

Multiplicative compensation (*moving one weight further from balance point counteracted by putting more weight on the other side*)

Equilibrium of physics systems involving 3 or more variables

Proportional thinking

Physical conservations involving ‘models’ (e.g. displacement volume)

It can be seen that in principle the descriptions of thinking of both these stages are sufficiently rich in variety to encompass most of the agenda of school learning in science and mathematics.

1.2 Ages and Stages

Unfortunately, by basing his work on the observation of ‘good subjects’ — a strategy typical of his earlier biological training—Piaget did put into circulation two false pictures of psychological development: that the development of formal operations occurred in all people by the age of 16, and that development first of concrete and then of formal operations is tied closely to age. In the late Sixties and Seventies, when evidence to the contrary began to appear, this led to widespread rejection of the whole corpus of the Genevan work. As we will see, if attention is confined to the top 20% of the population, Piaget’s age/stage picture is nearly true (actually only the top 13% achieve mature formal operations, 3B, by the age of 16).

Two replications of Piaget’s work on representative population samples shows a very different picture. Shayer, Küchemann, & Wylam,(1976) and Shayer & Wylam,(1978), using three Piagetian tests reported a survey of 14,000 children between the ages of 10 and 16, as part of the work of the CSMS research programme¹. Already by the age of 14 24% of the population are at the early formal level or above as can be seen in Figure 1. But half the population have not completed their full development even to the concrete generalisation (2B*) level! Cognitively, this is what the full population of 14 year-olds is actually like: a most important statistic for applied educational research.

Figure 1: Cognitive range of British 14 year-old population

¹ CSMS: *Concepts in Secondary Mathematics in Science*. Research programme funded by the Social Science Research Council at Chelsea College, University of London, 1974-1979.

1974/75 CSMS survey of 14,000 children between the ages of 10 and 16: Data for 14 year-olds

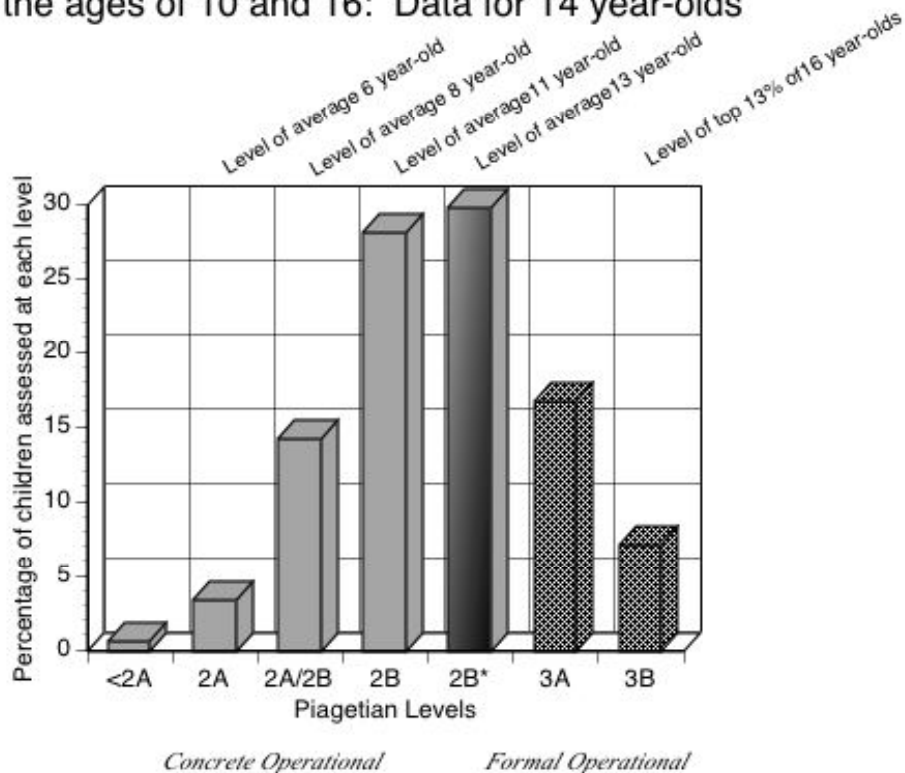

In the monograph Shayer, Demetriou & Pervez (1988) children between the ages of 5 and 10 were surveyed. A similarly wide spread of development at each year of age was found, but the most striking statistic was that in each of the countries Greece, Pakistan and Australia, already by the age of 7/8 20% of the samples were at the mature concrete level (2B) on at least 2/3rds of the tasks they were tested on. Our hypothesis is that it is these children, at the concrete generalisation level (2B*) by the age of 11, who are then ready, as Piaget described, to develop formal operational thinking during adolescence.

1.3 The necessity of intervention

If one consults the medical literature on child development (Tanner, 1978) graphs of, say, children’s height against age show a very strong relation between height and age, with the variation around the mean at any one year quite small. The interpretation of this is that—at least in a first-world nation by the Sixties—the variation is due to genetic differences. The environment is favourable to this aspect of growth. But if a factor more obviously affected by environmental differences like weight is inspected, the variation around the mean is greater. Thus a possible interpretation of Figure 1 is that the general environment is very unfavourable to the universal development of cognition. On this view Piaget’s age-stage view of development, which does fit the top 20% of the population, can be interpreted

as describing the genetic programme all are born with, but most, at present, do not realise. His term for this was ‘the epistemic subject’.

The reason this matters for education is that much of the agenda of secondary school science and mathematics requires formal operational thinking for its comprehension. For example, in mathematics the moment one is into generalised number and algebra, formal modelling is implicit (Halford, 1982, Collis, 1978). Figure 1 indicates that between 70 and 80% of the 14 year-old population would be barred from further participation—‘I was never any good at maths’. On the hypothesis of the genetic potential being still present in all adolescents, the only way the situation could be changed would be through a school-based intervention designed to boost the transition from concrete to formal operations. And the only way the hypothesis could be justified would be if the intervention were successful both in terms of cognitive development and achievement in mathematics. Such considerations led to the *Cognitive Development in Mathematics Education* project (CAME)². But this would not have been attempted had not an earlier intervention project using the same methodology in the context of science been successful (Shayer, 1999). In a paper in the current issue of the sister journal to this one (Shayer & Adhami, 2004) the case was cited of a school with an intake around the National average, whose previous 14 year-olds had 25% at the early formal or above level, having 65% at this level after a two-year intervention, with comparable gains on National exams three years later.

1.4 The context of mathematics

Few would deny that mathematics makes strenuous demands on student’s thinking and comprehension. Thus in principle it would be particularly favourable as a context for promoting thinking. But in comparison with arts subjects and science (except for mathematical aspects of physics) there is an important difference. The language of mathematics itself is so powerful that it lends itself to the production of procedures which can deliver a result even if students using the procedure have little, if any, understanding of what they are doing. An example would be ‘the rule of three’ for operating a proportionality. Thus in designing *Thinking Maths (TM)* activities two important principles were used. A context would be chosen for a maths concept that would contain different levels of achievement, ranging from mature concrete to mature formal, each of which would fulfil the Bruner hypothesis:

‘...any subject can be taught effectively in some intellectually honest form to any child at any stage of development.’ (Bruner, 1968, p44)

In this way all students can contribute to the agenda of the lesson, and all have the opportunity to progress from their current level.

² *Cognitive Acceleration in Mathematics Education I* (1993-1995) project funded by the Leverhulme Foundation. *Cognitive Acceleration in Mathematics Education II* (1995-1997) project funded jointly by the ESRC and the Esmée Fairbairn Trust.

Second, the conduct of the lesson would be focussed on the students constructing for themselves not just algorithms or procedures, but the *reasons* for the procedures and how they relate to other aspects of mathematics.

1.5 The Vygotskian contribution

In recent article (Shayer, 2003) a detailed case is made that Piaget's and Vygotsky's contributions to the psychology of cognitive development are complementary to each other. Vygotsky's concept of the Zone of Proximal Development (ZPD) presents two faces bearing on cognitive development. The first—illustrated in great detail in every published book of Piaget's—is that completed skills (that lead to instant success on psychometric test items) are not all that are in children's present minds. In addition there are many schemas in different degrees of completion which one day will surface as completed skills—hence 'Proximal'. But the second face is that there is substantial porosity between individual children's minds and those of their peers in the same social milieu. When children are collaborating in some learning task they share a common ZPD which can result in gains for each of them. Vygotsky's technical term for this is 'mediation'. Much of individual children's cognitive development is not done by each constructing concepts for themselves. Instead, when a child's ZPD for that concept may already be a half or three-quarters completed, seeing a successful and completed performance by another child like themselves results in their internalising instantly the whole concept, *mediated* by the other child.

As will be seen this view of cognitive development underlies much of the style in which the CAME lessons are conducted. Teachers need to take a Piagetian view of what is implicit in the maths, but only if, in addition, they conduct the lesson on a Vygotskian view of psychological development, will they be successful. Both views are necessary, and need to be integrated in their teaching skills.

2. The methodology of the CAME project

As in the earlier intervention research in the science context (Shayer, 2000), the assumption was made that a period of at least two years in the lives of adolescents was required if the effects of an intervention were to be permanent for them. This period was suggested by analysis of previously reported data on the effects of Feuerstein's Instrumental Enrichment programme (Feuerstein, Hoffman & Miller, 1980) as part of Shayer's replication of that programme (Shayer & Beasley, 1987) where effect-sizes of over one standard deviation on Raven's Matrices and a Piagetian test were found. Students on entry to secondary school at the age of 12 (Year 7: Y7) would receive *Thinking Maths* (Adhami, Johnson & Shayer, 1998) lessons at a rate of about one every 10 days during this period, and their maths teachers would also be encouraged to 'bridge' the teaching strategies used in these lessons into the context of their regular maths teaching. In this way students' learning might be made subject to a multiplier effect in all maths lessons.

2.1 *The context of mathematics*

For CAME little of the research conducted at Geneva by Piaget was available to cover the learning involved in secondary school mathematics. For the cognitive aspect, assessing in Piagetian terms the level of thinking demanded ('cognitive demand') for each achievement in mathematics was done partly in terms of a taxonomy initially developed for the field of science (but including mathematical descriptions) in chapter 8 of Shayer & Adey (1981). This was supplemented in considerable detail with the partly theoretical partly empirical work of the GAIM project³, itself directed by one of the original members of the CSMS team in the 1970s (Brown, 1989; 1992). In order to assess student progress during each year of secondary education on an individual basis the GAIM team produced behavioural descriptions of competence at some 15 different levels in nine major areas of mathematics, called 'strands'. On average a student was expected to progress through one level a year (starting with a median level of 5 in Year 7, the first year of secondary education at 12), but some students would progress faster than this so that they could be promoted to more demanding work. The levels were described initially with reference to the findings of the CSMS project that had been underpinned already in terms of a Piagetian interpretation, but were then subjected to further empirical fine-tuning by the teachers' use of them in assessing their students.

It can be seen that this criterion-referenced testing process developed by the GAIM team succeeded in bridging the chasm between ability and achievement that the behaviourists signally failed to do, and it is sad that the British Government eventually withdrew its approval in line with a policy of returning to a mainly final-exam version of General Certificate of Secondary Education (GCSE) taken by all students at 15/16.

2.2 *The CAME teaching strategy*

The mathematical strands featured in the work of GAIM were taken as the equivalent of the concrete and formal schemata reported in Piaget & Inhelder (1958) in the context of science. Each strand represented a key theme or 'flavour' underlying mathematical thinking. In designing *Thinking Maths* lessons two principles were used. First, as far as possible the set of 30 lessons would sample the principal strands, and later lessons would continue higher the agenda of the earlier ones. Second, contexts would be chosen which allowed some two or three different levels of achievement for different students, depending on their current level of development, rather than having just one aim. This strategy is shown in Table 1. Each lesson is focused on a major strand—shown as a solid black circle. But inevitably, maths being an

³ GAIM: Graded Assessment in Mathematics Project of the Inner London Education Authority

inter-related activity, other strands will also be implicated—shown as empty circles. In this way the whole agenda of mathematics would be addressed in a spiral curriculum going round the whole spectrum.

Table 1: The CAME lesson set

Secondary CAME Thinking Maths lessons by strands (1997)

	Lesson	Number Relations	Multiplicative Relations	Functions	Expressions & Equations	Geometric relations	Orientations and Shape	Data Handling & Probability	Range of Piagetian levels				
									2A	2A/B	2B	2B*	
1	Roofs			●	○		○						
2	Tournaments		○	●	○								
3	Operating on numbers	●	○										
4	Best size desk						●	○					
5	Length of words							●					
6	Direction and distance	○					●						
7	Two-step relations		○	●	○								
8	Relations		●	○	○	○	○	●					
9	Exploring the rectangle				○	○	○	●					
10	Rectangle functions				○	○	●	○					
11	Missing digits	●	○										
12	Functions		●		○	○							
13	Border and inside		○	●	○	○	○						
14	Circle relations		○		○	○	●						
15	Circle functions				○	○	●						
16	Three dice	○						●					
17	Sets and sub-sets	●				○	○						
18	Correlation scatters	●	○					●					
19	Accuracy and errors		○		○			●					
20	Heads or tails?			○	○			●					
21	Expressions & Equations				○			●					
22	Comparing correlations		○	●	○								
23	Rates of change	○						●					
24	Data relations		○			●							
25	Triangle ratios			○	●								
26	Chunking & Breaking up		●	○									
27	Accelerating acceleration		○	○		●							
28	Graph of the rotating arm		○	●									
29	Straight line graphs		○	○				●					

The CAME methodology can be illustrated by Activity 7: Two-Step Relations. The major strand featured is Functions. Figure 2 shows the pupils' worksheets.

Figure 2: CAME Two-Step Relations lesson

Work in Pairs ; Names:
Date:

Two step relations

1. Twigs and Leaves:

Twigs: --
Leaves: --

Twigs: --
Leaves: --

Twigs: 5
Leaves: --

Twigs: -- (choose)
Leaves: --

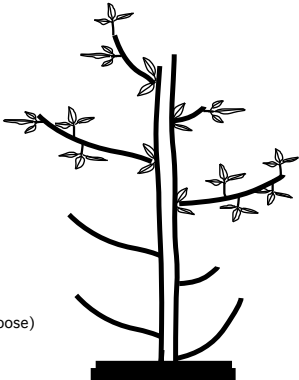

Twigs: --
Leaves: -

Twigs: --
Leaves: -

Twigs: 0
Leaves: --

Twigs: 1
Leaves: --

- Explain in words how to find the number of leaves if you know the number of twig:
- Complete this half-word half-symbols sentence:
Number of Leaves = +
- Write the expression in symbols. Use the letter **T** for number of twigs, and the letter **L** stands for the number of leaves,
- Fill in the table with your results in some order:

Number of Twigs	0	1							
Number of Leaves									

2. Black and white tiles

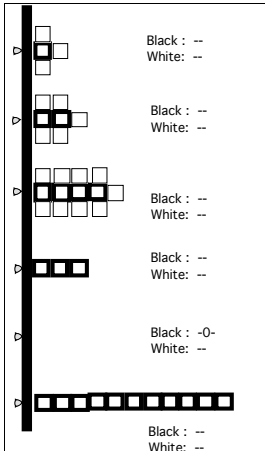

Black : --
White: --

Black : --
White: --

Black : --
White: --

Black : --
White: --

Black : --0-
White: --

Black : --
White: --

First work out the pattern and fill in the numbers for black and white tiles in the box. Then answer these:

- How many white tiles will be needed for :
100 black tiles:
17 black tiles :
333 black tiles :
- Explain in words how to find the number of white tiles if you know the number of Black tiles:
- Complete:
Number of White tiles = +
- Write an expression in short hand. Use **W** for the number of white tiles and **B** for the number of Black tiles

5. Fill in the table with your results, in some order:

Number of Black tiles	0	1							
Number of White tiles									

- Compare this pattern with the twig and leaf's pattern. Write a sentence on what is similar between them:
- What is different:

3. Graphs

- Plot the pairs of numbers for twigs and leaves. Describe the graph pattern.
- Plot the pairs of numbers for Black and White tiles. Describe the pattern
- What is similar about the two patterns?
- What is different?
- Which of the three methods of showing the patterns you think is better: words and symbols, tables, or graphs? and why?

Leaves

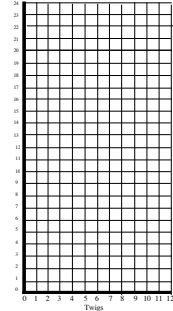

White tiles

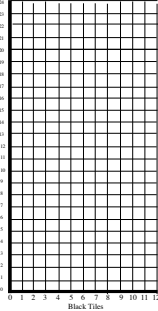

The overall aim of the activity is functional relations expressed in algebraic terms. But as can be seen from Table 1, part of the function concept involves looking at the number relations of, e.g. Twigs and Branches in multiplicative rather than additive terms. Then to express the functional relation in generalised number terms insight into how to translate the relation as an algebraic expression would be needed.

Entry into the task requires only descriptive concrete schemata (2A/2B, middle concrete to 2B, mature concrete). Getting as far as a generalisation in words,

Number of leaves = number of twigs times 3 plus 2 leaves at the trunk

would be still at the concrete generalisation (2B*) level. But making the jump into constructing the letter language of generalised number is the first step into formal thinking. So likewise is interpreting the two graphs in terms of their different expressions.

This is the Piagetian aspect of the lesson. But the Vygotskian social agenda can also be read into the context. Every TM activity involves at least two 3-Act episodes. The Twigs and Leaves episode is introduced by some 5 to 10 minutes of whole class discussion managed by the teacher in which pupils are asked first to explain to each other what they think the worksheet is about. Then pupils are asked to attempt at least one of the problems and encouraged to discuss possible answers. This first Act is called Concrete Preparation, where the intention is to begin the process of establishing a shared ZPD. Then the pupils in pairs or small groups are given 10 to 15 minutes to work together on the four worksheet questions, with the expectation of having to give an account of their ideas to the rest of the class. In this second Act the collaborative learning involved in small group work and discussion takes place. At this point the teacher, rather than spending time going round to groups ‘helping’ instead listens, see and notes where each group has got to, and, depending on the different aspects of working on the underlying mathematical ideas he finds, makes a plan of who, and in what order, he will ask the groups to contribute to Act.3. He may occasionally throw in a strategic question if he sees a group is stuck. Act 3 is whole class discussion for a second time and, when well conducted, gives the maximum scope for a communal ZPD. It is not necessary for all of the class, in Act 2, to have tried solutions to all of the worksheet: the teacher uses judgement to choose the time when enough variety of ideas have come up in at least some of the groups. As each group reports its ideas—or those which the teacher asks them to address—other pupils are encouraged to ask questions, and so all the strategies and queries produced by all the groups are made available publicly so each pupil in the class has the chance to complete their ZPD with respect to each of the possible concept levels, even if their group did not produce it.

The Act 3 whole class discussion is then steered into a brief concrete preparation to Worksheet 2, and the second 3-Act episode then continues, conducted in the same style, but faster. Finally, if time permits, the brief Worksheet 3 on graphs of the relations is attempted.

The implications of this for the actual strategies of teaching can be inspected in the following account of one of the CAME teachers with a class in what was the worst of the 30 schools in the school district (County)—worst, that is, in terms of the ability range of the school intake and also in National tests and exams. In Table 2 these notes, together with the comment at the end, were both part of the

research record and also, with that teacher's permission, were fed back to the other three maths teachers in that school as part of their professional development. 'P' is the abbreviation for pupil, and 'T' is that for the teacher.

Further specifics of the CAME methodology may be inspected in Shayer & Adhami (2004).

3. The conduct of the CAME intervention

3.1 The sample, timing and evidence collected

In the first two years of the research (1993-95) four pilot classes taught by the Heads of Maths in four schools were chosen for the trial and development of the Thinking Maths lessons. Twelve schools then volunteered for the CAME project itself in the subsequent two years (1995-97). Two schools within reach of Cambridge and two schools in the London area, named 'Core' were visited frequently by Shayer and Adhami; the others, named 'Attached' received professional development (PD) only through the attendance of their Heads of Department at King's College. In each school all Y7 classes were involved, and the intervention continued until the end of Y8 (students were 12 to 14 years of age in their first two years of secondary education). Pre- and Post-tests were given to all students, using the Thessaloniki Maths test (Demetriou, Platsidou, Efklides, Metallidou, & Shayer, 1991). Subsequently, after the end of Year 11 (the 5th year of secondary schooling), the students' General Certificate of Secondary Education (GCSE) results for Maths, Science and English were collected.

3.2 The Thessaloniki Maths test (TM)

This test was derived from the original research of Demetriou, et al.(1991), mentioned above, establishing the measurement of quantitative-relational abilities. It contains items featuring three aspects of mathematical activity: Use of the 4 operations; Algebra, and Proportionality, covering a wide range of levels from middle concrete (2A/2B) to mature formal (3B). It is therefore particularly appropriate as a test of general mathematical ability for studying intervention, as can be seen from Figure 3.

Figure 3. Scaling of Items in Thessaloniki Maths Test

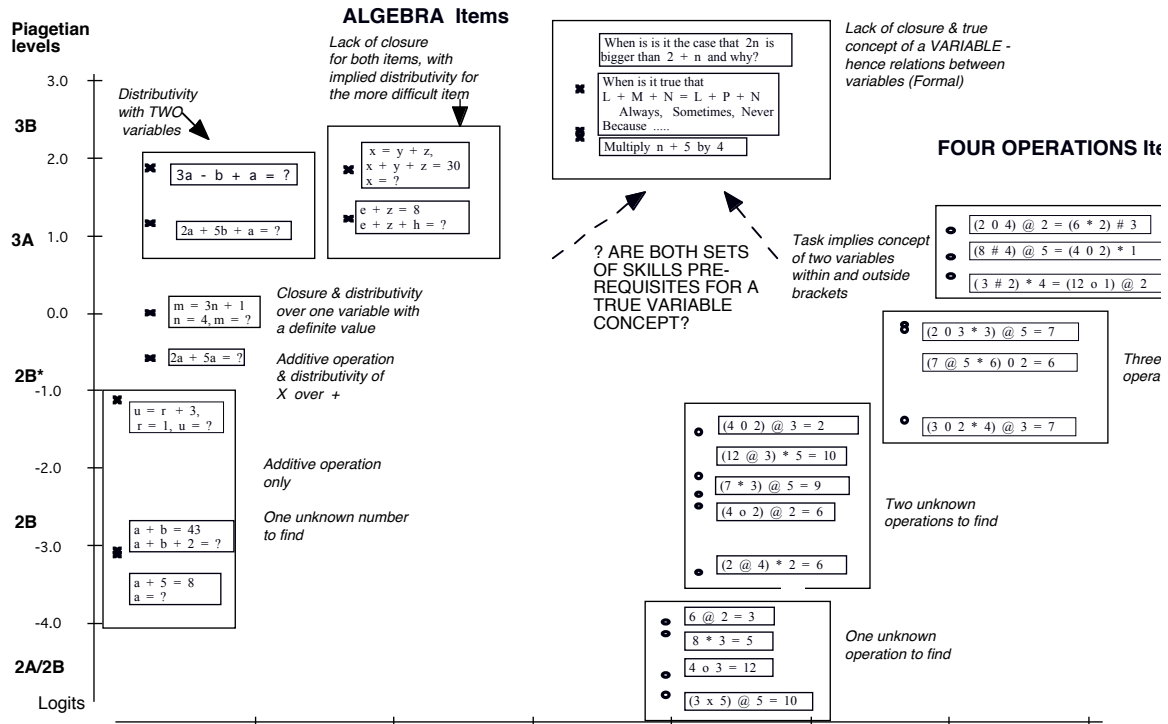

In Figure 3 the items for two of the three sets are shown at the levels at which they scale (with two exceptions all the proportionality items—derived from the research of Noelting (1980)— scale at the early formal (3A) to mature formal (3B) level). The 4 Operations items contain one or more operations each given an arbitrary symbol, and the pupil has to choose the right operation for each (derived from the research of Halford, 1982).

Subsequently the test was standardised in England in terms of the CSMS norms (Shayer, Küchemann & Wylam, 1976) using Y7 and Y8 data from four schools where the students had also had administered one of the Piagetian tests used in the CSMS survey. In effect these four schools serve as Controls for this study.

3.3 Immediate post-test

The TM test was administered to all classes in September 1995 at the beginning of Y7, and again early in July at the end of Y8, with the exception of school Attached 8 who did not administer this post-test. In Table 2 the Pre- and Post-test means for each school are shown, together with the effect-size computed in terms of the standard deviation of the Y8 controls. The scale used for the data is an equal-interval scale where 5= Mature Concrete; 6=Concrete Generalisation, and 7=Early Formal. The predicted values were obtained from the TM test norms, given the school pre-test mean.

Table 2 Pre-Post test school means on the Thessaloniki Maths test

School	Post-test			
	Pre-test	Predicted	Obtained	Effect (SD) p

Core 1	6.08	6.49	7.00	0.41	<.01
Core 2	5.32	5.79	6.02	0.18	<.05
Core 3	5.03	5.52	5.66	0.13	n.s
Core 4	5.45	5.91	6.47	0.52	<.01
Attached 1	5.63	6.08	6.58	0.49	<.01
Attached 2	5.99	6.41	7.02	0.56	<.01
Attached 3	4.77	5.29	5.59	0.28	<.01
Attached 4	5.69	6.13	6.15	0.01	n.s.
Attached 5	5.30	5.78	6.17	0.38	<.01
Attached 6	5.29	5.77	5.97	0.2	<.025
Attached 7	5.68	6.13	6.76	0.62	<.01

Overall mean 0.344 SD

The moderate overall school effect-sizes hide a wide variation class by class within each school, which is now shown in Figure 4. The school means are shown in black.

Figure 4: Class gains above expected gains over two years

Figure 4: Class gains above expected gain over two years

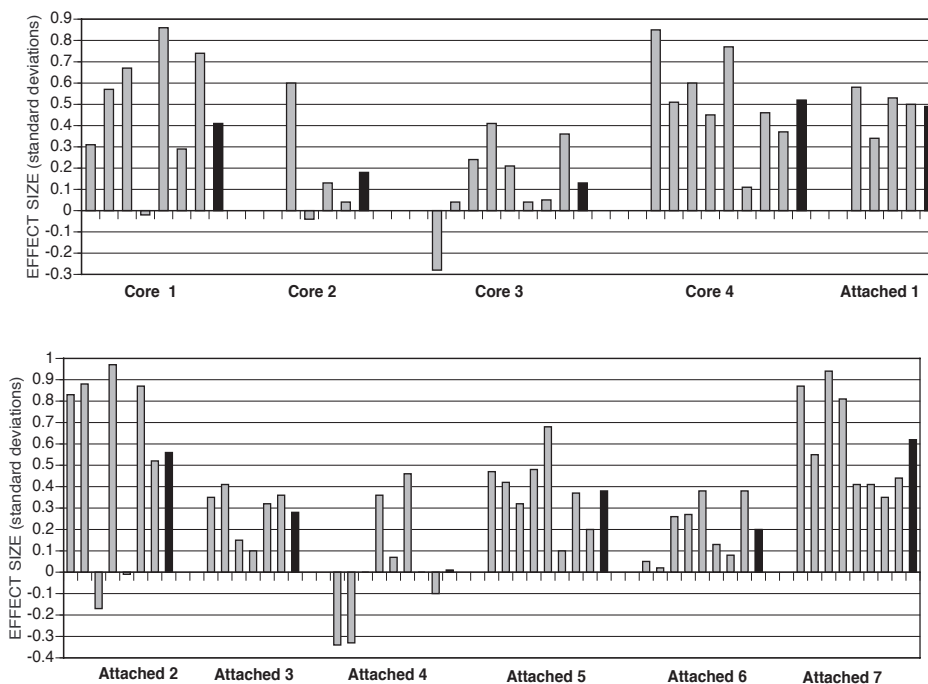

No-one familiar with secondary school departments is likely to be surprised by this variation: it can clearly be seen that quite large effects have been achieved by some classes. Figure 5—a stem-and-leaf diagram of the class effect-sizes—is even more revealing.

Figure 5: Effect-sizes on Thessaloniki Maths test: all classes

σ													
0.9	0.94	0.97											
0.8	0.81	0.83	0.85	0.86	0.87	0.87	0.88						
0.7	0.74	0.77											
0.6	0.6	0.6	0.67	0.68									
0.5	0.5	0.51	0.52	0.52	0.53	0.55	0.56	0.57	0.58				
0.4	0.41	0.41	0.41	0.42	0.44	0.45	0.46	0.46	0.47	0.48	0.49		
0.3	0.31	0.32	0.32	0.34	0.35	0.35	0.36	0.36	0.36	0.37	0.37	0.38	0.38
0.2	0.2	0.21	0.24	0.26	0.27	0.29							
0.1	0.1	0.1	0.11	0.13	0.13	0.15							
0	0	0	0.02	0.04	0.04	0.04	0.05	0.05	0.07	0.08			
-0.1	-0.04	-0.02	-0.01										
-0.2	-0.17	-0.1											
-0.3	-0.28												
-0.4	-0.34	-0.33											

It can be seen that the distribution is tri-modal—suggested medians for each mode are in bold—with 30 classes ranging between ± 0.3 standard deviations, which is just about the expected range for a zero effect; 37 classes range around a moderate effect-size of about 0.5 SD, while 11 classes show a large effect of the order 0.8 to 0.9 SD.

Perhaps the top mode shows the effects that can be obtained by teachers who have thoroughly mastered the new teaching skills required, while the middle mode shows quite worthwhile effects being used by teachers for whom this is the first time they have practiced them.

3.4 GCSE 2000 results

The intention of the CAME project was to enhance the cognitive development of students through approaching their mathematics learning in a reflective way. Given that intention it could then be predicted that the learning ability of the students would in general be increased as an effect of their becoming more intelligent. An alternative prediction would be that only their mathematics achievement would be enhanced. In order to investigate these two possibilities—and of course the nul hypothesis that no effect whatsoever had occurred—the GCSE results in Mathematics, Science and English of all the students in the 12 schools of the project were collected.

Data on a similar number of Control schools were collected whose average level of intakes covered the same range as the CAME schools (approx. the 18th to the 65th percentile in National terms). These were schools receiving professional development (PD) from King’s College in the CASE project, all of whom were pre-tested at the beginning of Y7 with PRT II: Volume and Heaviness, the same CSMS test used to set the norms for the Thessaloniki Maths test. The classes sitting GCSE in the year 2000 had received neither the CASE nor the CAME intervention. This procedure would introduce some ‘noise’ into

the data due to slight variations in the school intake from year to year, but the assumption was made that this variation is random (the Y7s tested were either from 1996 or 1997, whereas the CAME schools were pre-tested in 1995). The National GCSE 2000 data on the whole population would serve as a check on the representativeness of the sample of Control schools.

Figure 6 shows how the data were analysed.

Figure 6. Added value in GCSE 2000 for CAME schools

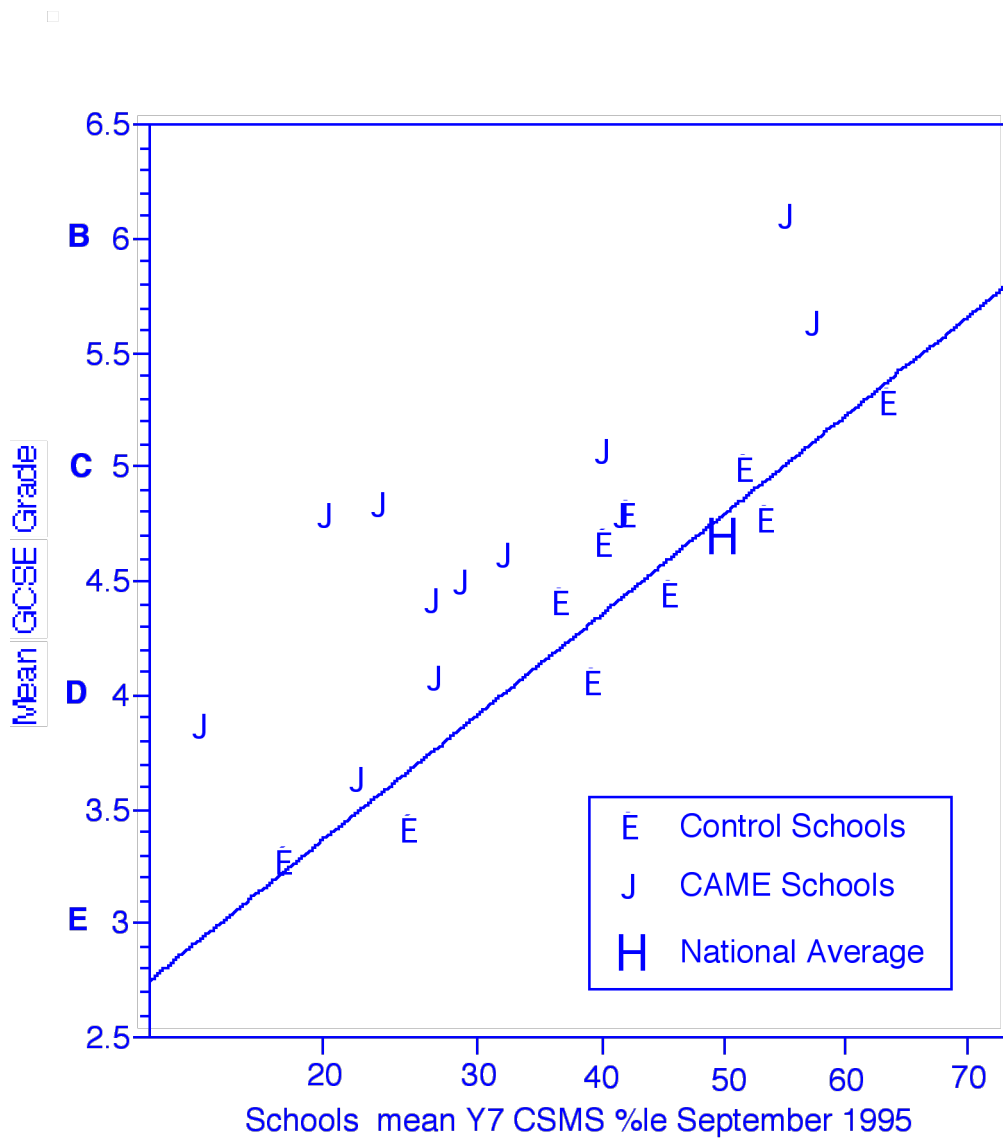

The mean GCSE grade for each school was plotted against the mean percentile of their Y7 intake (the percentages were plotted as logits in order to linearise the scale for percentages—hence the non-linearity of the scale as shown). Then the regression line for GCSE grades by logit percentile for the Control schools was plotted. The added value in GCSE grades for each CAME school is then the distance above the regression line for its data point plus the extent to which the regression line lies above the National average. These effects for GCSE maths are shown in Table 3.

Table 3 Added-Value for GCSE maths for CAME schools

School	Maths mean grade			Added Value	Effect-Size	Significance
	predicted	Obtained	Residual			
National Average	4.79	4.70	-0.10	0.00		
Core 1	5.03	6.10	1.07	1.17	0.63	<.01
Core 2	3.78	4.08	0.30	0.39	0.21	n.s.
Core 3	3.51	3.64	0.13	0.23	0.12	n.s.
Core 4	4.03	4.62	0.60	0.69	0.37	<.01
Attached 1	3.39	4.80	1.40	1.50	0.81	<.01
Attached 2	3.58	4.84	1.26	1.35	0.73	<.01
Attached 3	2.95	3.87	0.92	1.01	0.55	<.01
Attached 4	4.45	4.80	0.35	0.45	0.24	n.s.
Attached 5	3.87	4.51	0.63	0.73	0.40	<.01
Attached 6	3.77	4.42	0.64	0.74	0.40	<.01
Attached 7	4.38	5.08	0.70	0.79	0.43	<.01
Attached 8	5.13	5.64	0.51	0.60	0.33	<.01

Mean 0.80 grade 0.44 SD

The mean added-value of 0.8 grade. may appear modest, but Table 4 shows that for the higher-ability students the gains are substantial—in three cases the proportion of students gaining C-grade or above was doubled.

**Table 4
Added-value for GCSE maths in terms of C-Grade or above**

School	Maths % C-Grade+			Significance
	Predicted	Obtained	Added-value	
Core 1	54.6	74.4	18.2	<.01
Core 2	27.5	30.3	1.2	n.s.
Core 3	22.8	22.2	-2.2	n.s.
Core 4	32.3	50.0	16.1	<.01
Attached 1	21.0	47.3	24.7	<.01
Attached 2	24.1	50.4	24.7	<.01
Attached 3	15.0	29.6	13.0	<.01
Attached 4	41.3	48.0	5.1	n.s.
Attached 5	29.3	40.2	9.3	<.05
Attached 6	27.4	47.1	18.1	<.01
Attached 7	39.8	53.0	11.6	<.05
Attached 8	56.9	75.9	17.4	<.01

Note: no Effect-sizes are given here because the standard deviation of the %C-grades and above statistic cannot be computed from the DfES National statistics.

For maths at least it seems that the TM post-test gains shown in Table 2 predict even larger added-value at GCSE three years later. From Figure 7 it can be seen that there is substantial correlation between the two:

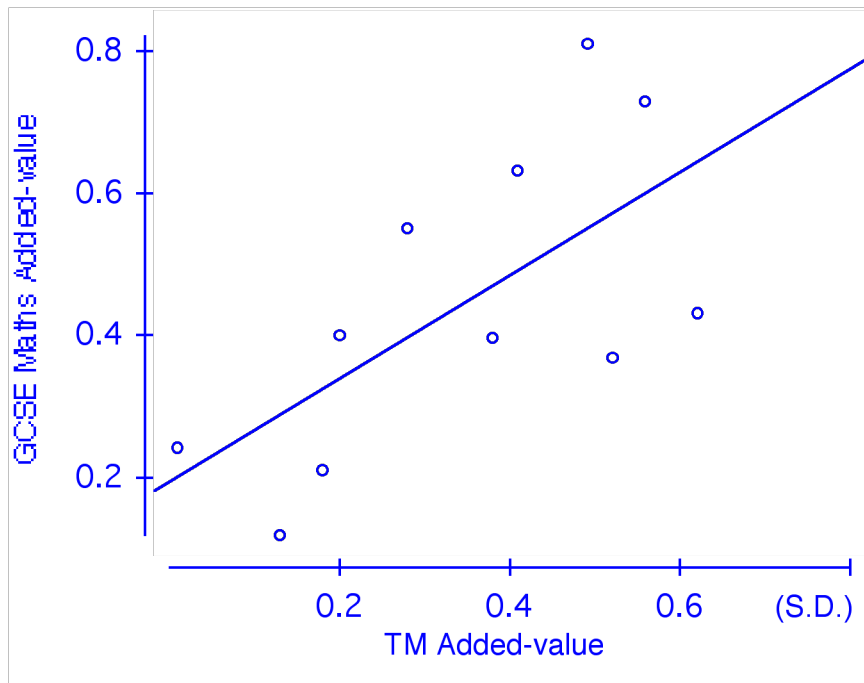

Figure 7: Correlation between gain scores of GCSE 2000 Maths and Thessaloniki -Post test 1997 both in relation to Thessaloniki Pre-test 1995

In order to test whether the CAME intervention had a general effect on the cognitive development of the students it is now necessary to inspect the Added-Value for the other GCSE subjects. Tables 5 and 6 give the corresponding effects for science and English.

Table 5 Added-Value and Effects for science and English

School	Science			English		
	Added Value (Grades)	Effect-size (S.D.s)	sig.	Added Value (Grades)	Effect-size (S.D.s)	sig.
Core 1	0.67	0.39	<.01	0.70	0.44	<.05
Core 2	0.28	0.16	<.05	0.27	0.17	<i>n.s.</i>
Core 3	0.13	0.08	<i>n.s.</i>	0.54	0.33	<.05
Core 4	0.68	0.40	<.01	0.66	0.41	<.05
Attached 1	1.05	0.62	<.01	0.49	0.31	<.05
Attached 2	0.65	0.38	<.01	0.65	0.40	<.05
Attached 3	0.54	0.32	<.01	0.53	0.33	<.05
Attached 4	0.55	0.32	<.01	0.43	0.27	<i>n.s.</i>
Attached 5	0.97	0.57	<.01	1.05	0.65	<.01
Attached 6	0.03	0.01	<i>n.s.</i>	0.18	0.11	<i>n.s.</i>
Attached 7	0.21	0.13	<i>n.s.</i>	0.30	0.19	<i>n.s.</i>
Attached 8	0.36	0.21	<i>n.s.</i>	0.47	0.29	<.05
Means	0.51	0.30		0.52	0.32	

Table 6 Added-value for GCSE Science and English in terms of C-Grade or above

School	Science % C-Grade+				English % C-Grade+			
	Predicted	Obtained	Added-value ¹	Sig.	Predicted	Obtained	Added-value	Sig.
Core 1	51.5	67.0	12.8	<.025	62.3	79.6	20.3	<i>n.s.</i>
Core 2	23.9	33.3	8.4	<i>n.s.</i>	32.0	39.4	8.1	<i>n.s.</i>
Core 3	19.4	24.5	4.3	<i>n.s.</i>	26.3	43.0	26.3	<i>n.s.</i>
Core 4	28.5	50.9	19.6	<.01	37.6	60.6	21.9	<i>n.s.</i>
Attached 1	17.7	46.4	28.0	<.01	24.1	40.3	18.0	<i>n.s.</i>
Attached 2	20.6	36.4	16.0	<.01	27.9	48.2	20.7	<i>n.s.</i>
Attached 3	12.3	26.9	19.9	<.01	16.9	37.3	24.5	<.05
Attached 4	37.6	64.0	22.2	<.01	47.9	61.0	13.0	<i>n.s.</i>
Attached 5	25.6	54.8	25.7	<.01	34.0	68.9	31.1	<.025
Attached 6	23.8	29.6	4.3	<i>n.s.</i>	31.8	40.4	9.2	<i>n.s.</i>
Attached 7	36.0	43.0	4.1	<i>n.s.</i>	46.2	57.4	11.1	<i>n.s.</i>
Attached 8	53.9	60.0	3.0	<i>n.s.</i>	64.6	80.0	18.7	<i>n.s.</i>

¹ This value is less the residual for the National Average which was above the regression line

As with the mathematics percent C-grade data the regressions were calculated with logits rather than raw percentages (to give the variable an equal-interval scale), which explains the slight discrepancies between the added-values and the differences between predicted and obtained.

In the case of science and English the effect-sizes are comparable with the Post-test results on the TM post-test at the end of Y8. The lower statistical significance for the English effects is due to the lower correlation between the Pre-test and the Control English grades giving greater variation around the regression line.

4. Concluding discussion

The original intention of the research presented here was to use mathematics learning as a context for enhancing the cognitive development of some 60 to 70% of the adolescent population. Students' achievement in mathematics was not ignored, but if it was found to increase it was assumed that this would be due to the students' hoped-for increased learning ability. This intention will now be examined.

Although the Thessaloniki Maths test is placed in the context of maths it was in fact designed by Demetriou et al. (1991) as a general test of quantitative relational abilities. The strong correlation between the added-value scores on this test in 1997, and the added-value scores in GCSE Maths in 2000 shown in Figure 7 is some evidence for the validity of the original intention. Although the effects shown in Tables 5 and 6 are lower than for mathematics in Tables 3 and 4 they are substantial enough to support the hypothesis that students' intelligence in general has been enhanced by the CAME intervention. While it could be argued that there is enough mathematical content in science to explain the science effects in terms of student's enhanced competence in maths, the same cannot apply to the effects in GCSE English, taken three years after the end of the CAME intervention. In order to see if there is more in the research data than originally intended the cognitive effects relating to the social agenda will now be examined in more detail

4.1 The cognitive agenda

The question may be asked, What *is* the 'intelligence in general' that it is claimed has been enhanced? Piaget's (1971) view was that it is the degree of sophistication of children's logical powers, which underly performance in whatever context they are directed to. Looked at from the point of view of memory research (Baddely, 1990) it would be the number of 'chunks' that can be handled in short-term memory, and the efficiency with which each chunk can be embodied with content (Case, 1992). But in terms of the psychometric tradition it would be what, ever since Spearman (1927), has been called 'g', variance in common between different psychological batteries. This might be considered as just factor-analytic artefact, generated by the mathematical models used to abstract from the specifics of the test-data. But a recent study (Duncan, 2000) appears to provide a neuro-psychological location for a general processor. He took two tests, both of which had high 'g' loadings—one of verbal reasoning and the other

a spatial test. Subjects were asked to work on the items while undergoing a PET scan. Activity was, of course, found in the areas of the cortex involved in verbal and spatial specifics respectively as expected. But common to both was activity in the same area of the lateral frontal cortex, an area associated with general information-processing, executive control functions and monitoring the contents of working memory. This supports Piaget's view, but perhaps we need something more specific than his logic-based model. In Demetriou (2005) tests of quantitative-relational, causal, and social thinking, together with one of drawing with aspects of metacognition of each, were given to 840 students aged between 11 and 16. Structural equation modelling on the battery revealed both domain-specific and domain-general ('g') systems. Demetriou argued that 'self-monitoring and self-representation' —that is, metacognition— 'are integral components of g and that the stronger g is the more advanced these processes are'. His paper is far more complex than space allows here for its presentation, but it does provide an understanding of why work in a specific domain, undertaken in the right way, is the only likely way by which children's domain-general thinking can be affected. This would follow also from Duncan's (2000) paper: unless there are domain-specifics for the brain to abstract from or relate to, no improvement in 'executive control' & can take place. But, while metacognition is undoubtedly a feature of general thinking ability and was indeed fostered in the conduct of the TM lessons, it is not argued that it is the *cause*—in a transfer of training sense—of the improved cognition of the pupils. 'Thought is an unconscious activity of the mind', Piaget (1950, p,22) quoted approvingly from Binet. Ability to handle more aspects of reality, and more complex relations between them, in any one thinking act in the context of maths should result—given exposure and experience in the quite different domain of English—to the ability to handle a comparable degree of complexity there as well.

4.2 The social agenda

Earlier it was asserted that the Vygotskian interpretation of cognitive development invokes the teacher managing peer-peer mediation rather than 'scaffolding' by adult-student mediation. There is some evidence in this study that supports this interpretation. In Figure 4 schools Core 1, Core 2, and Attached 2 all had remedial classes where the range of ability was very restricted and low (mean Pre-test values in the 2A/2B Middle Concrete range). In the case of Core 1 this was brought about by setting in maths throughout the year-group at half-term in term 1 of entry into secondary school (Y7). Core 2, in contrast, was a small comprehensive school with the lowest level intake in the county, who put all their bright children in the one class—the one with the effect-size of 0.6 SD—leaving two of the other three with a range that another school would have labelled remedial. Attached 2 had two remedial classes—the others

were much more heterogenous. Core 4, on the other hand, had a strict mixed-ability policy maintained right through to the end of Y9, and so can serve as a comparison.

In Attached 2 it can be seen that there is one class with a virtual non-effect, and next to it is a class with the highest effect-size showing (0.97SD). Both classes were taken by the *same* teacher: the difference is that the non-effect class was one of the remedial ones. Likewise in Core 2 the two remedial classes were those with effect near zero. The teacher of one of them, the Head of Maths, was very skilled in promoting collaborative learning and also had a good grasp of the cognitive agenda. In Core 1 it was the lowest of the remedial classes that had the zero effect. By contrast all but one of the mixed-ability classes in Core 4 had substantial effect-sizes.

The interpretation suggested is that, despite evidence of two good CAME teachers taking remedial classes in two schools, their skill was in vain because of a lack of higher-ability children in the class who could supply to the less able students the ‘successful performances’ they needed to witness to extend their ZPDs. Both in the collaborative small group work and in the whole class discussions the collective ZPD was too limited to act as a spur to their cognitive development.

Given this argument, perhaps one may look at a small piece of related evidence bearing on the issue of mixed-ability classes versus streamed (setted). In England all students are assessed at the end of their third year in secondary school by National tests (Key Stage 3—KS3) in science, mathematics and English, and each pupil’s results are reported in terms of what level they reached in terms of the 8 levels of learning achievement published in the National Curriculum (NC). In each of the three Core schools the median Y7 Pre-test Piagetian level on the TM test for all pupils subsequently achieving NC level 7, then level 6 and so on was computed and inserted into Figure 8. Thus the *lower* the mean TM Pre-test score at entry to secondary school for, e.g. all pupils assessed at NC level 6 three years later, the better was the school doing for them.

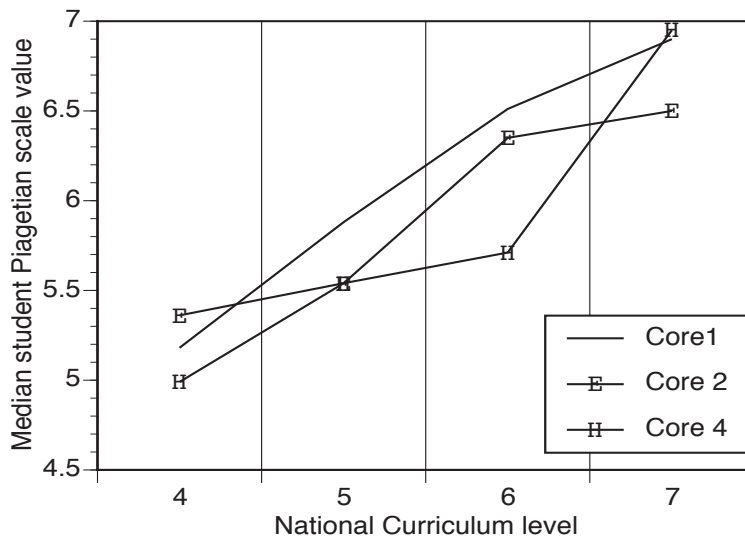

Figure 8: Median Y7 entry value for KS3 success at each NC level

It can be seen that, up to KS3 NC level 6, the mixed-ability school Core 4 consistently obtained National Curriculum levels from students of *lower* ability at entry to secondary school than the other two schools—for level 6 markedly so, and this is the level that predicts C-grade or above at GCSE, the level usually regarded as justifying further education in the subject for the student. For the only 3 students from Core 2 (the worst school in the district) who obtained level 7, it can be seen that the school had clearly enabled them to realise their potential. Core 1, the school which setted for Maths from term 1 in Y7, did no better for its very high ability students than Core 4 with mixed-ability classes, and for levels 5 and 6 demanded higher ability students at intake to Y7 than did Core 4.

4.3 The issue of Professional Development (PD) and further research

Twelve years on from the outset of the initial CAME research it is necessary to update a view of the original aims. At the time of its introduction it was perhaps acceptable in England to regard the English National Curriculum as defining the norm of instructional teaching. The idea of the CAME intervention was that by accelerating the cognitive development of students in the first two years of secondary schooling one might at least double the proportion of students able to access the objectives of normal instructional teaching in maths. In this paper evidence is given that this aim has actually been achieved for three of the CAME schools. Yet if ‘normal’ mathematics instructional teaching continues only to produce the dismal results for at least half the population in secondary schools reported in the original CSMS research from the 70s (Hart, 1981) both in achievement and motivation, it is now time to question this dichotomy.

First, just in relation to the CAME intervention itself, it seems doubtful whether the delivery of just 30 stimulating activities over a two-year period could itself have been responsible for the large effects on the students. The maths teachers were encouraged, as part of their PD, to establish connections between the agenda of the CAME lessons, and the contexts of their ordinary maths lessons using the same reasoning patterns. They were also encouraged to adopt the teaching skills they were using in the CAME activities into the social agenda of their other maths lessons. In effect many of them were taking a ‘Thinking Maths’ approach into all their teaching, and by implication encouraging their students to take a thinking approach to their learning, which seems to have affected their learning in other subjects as well. It was probably this ‘multiplier’ effect that accounted for the students’ marked development.

If this view is correct then perhaps it is better to regard CAME as being a constructive criticism of normal instructional teaching in maths itself? Such a view was certainly taken by Vygotsky in the late 20s (Shayer, 2003): *all* teaching in schools should be rethought so as to enhance the thinking of all students. Piaget’s view (Smith, 2002) of schooling was complementary to this: the individual *needs* the collaborative learning of ‘the collective’ in order to ‘to think and re-think the system of collective notions’. Some University Departments of Education currently use some of the CAME lessons as part of their work with teachers in initial training.

In two more recent research projects—CAME for the last two years of Primary school as part of the Leverhulme programme⁴ and the current RCPCM⁵, for the first two years described in Shayer and Adhami (2004) —the relation of the University research team to the project teachers has evolved. In all the projects teachers are being asked to enter into an interactive multilogue with their students in their Thinking Maths lessons where the overall script for the lesson is given but the conduct depends on the individual and collective responses, moment by moment, of the students. Somehow the teachers need to develop and internalise both the cognitive and the social aspect of the process described above. They are to ‘catch’ the process whereby they see the individual and collective ZPDs of their class and make the right moves to promote them. If their students are being asked to construct their learning through a collective and collaborative process then it follows that teachers cannot simply be *told* how to do it. They need to experience a comparable process in their professional development. Just as they ask their students to work on some maths task in small groups, followed by whole class discussion, they need to plan together a lesson or two, go away to teach it (ideally in small groups so that one teacher’s practice is observed and assisted by the others), and then discuss with each other the specifics of the different ways of how the children acted and how this relates to the script of the lesson and the cognitive and social

⁴ Leverhulme Numeracy Research Programme (1997-2002), Funded at Chelsea College by the Leverhulme Trust

⁵ Raising the Cognitive Potential of Children 5 to 7 with a Mathematics focus (2001-2004). Research Project funded by the ESRC.

agenda. The teachers' construction of their teaching process parallels their children's construction of mathematical concepts and skills. It is *their* construction that makes it real for them. The role of the University researcher is to offer ideas based on sound evidence-based research, not to instruct them how to use them. Thus the University research team relate to and are dependent on the teaching skills and ideas of the teachers they are working with. This is an interesting and demanding discipline for them to submit to and experience. Some of the teachers, on the basis of this experience, are then able to conduct PD for other teachers. Such an organic process could initiate exponential growth throughout the country's schools. It is very different from the 'cascade' model of PD still currently used, for example, by the Government education department (DfES) in England.

Thus we suggest that, if we agree with Vygotsky that ,

'...the only good kind of instruction is that which marches ahead of development and leads it; it must be aimed not so much at the ripe as the ripening functions. '(Vygotsky 1986,p188).

the better use of CAME would be for it to be part of a practice which allows its own evolution in the process whereby good previous instructional teaching in mathematics can be integrated with teaching skills suggested by CAME. Evidence-based research on the effectiveness of this evolution would be an essential part of the process.

References

- Adhami, M., Johnson, D. C., & Shayer, M.(1998). *Thinking Maths: the programme for Accelerated Learning in Mathematics*. Oxford: Heinemann Educational Books.
- Baddely, A. (1990). *Human Memory: Theory and Practice*, Hove: Erlbaum.
- Bloom, B.S. (Ed.) (1956) *Taxonomy of educational objectives: The classification of educational goals: Handbook I, cognitive domain*. New York: Longmans, Green
- Brown, M. (1989). Graded Assessment and Learning Hierarchies in Mathematics-an alternative view. *British Educational Research Journal*, 15, 2, 121-128
- Brown, M. (1992). *Graded Assessment in Mathematics. Teacher's Guide*. London: Nelson.
- Bruner, J. (1968). *Towards a Theory of Instruction*. New York: W.W. Norton.
- Case, R. (1992). *The mind's staircase*. Hillsdale, NJ: Erlbaum.
- Collis, K.F. (1978). Chapters 7 & 8 in, Keats, J.A., Collis, K.F.,& Halford, G.S. (Eds). *Cognitive Development: Research based on a Neo-Piagetian approach*. New York: John Wiley & Sons.
- Demetriou, A., Platsidou, M., Efklides, A., Metallidou, Y. & Shayer M. (1991). The development of quantitative-relational abilities from childhood to adolescence: structure, scaling, and individual differences . *Learning and Instruction*, 1, 1, 19-43.
- Demetriou(2005). Emergence, Nature and Functions of g: A Response to Kanazawa and an Alternative Model.(Article submitted for publication).
- Duncan,J.; Seitz, R. J.; Kolodny, J.; Bor, D.; Herzog, H.; Ahmed, A.; Newell, F. N.; Emslie, H.(2000). A neural basis for general intelligence. *Science* **289**(5478):457-60, 2000.
- Embretson, S.E.(1968). Diagnostic testing by measuring learning processes: psychometric considerations for dynamic testing, in *Test Design: Developments in Psychology and Psychometrics*, New York: Academic Press.

- Feuerstein, R. , Rand, Y., Hoffman, M., & Miller, M.(1980). *Instrumental Enrichment: an intervention programme for cognitive modifiability*, Baltimore: University Park Press
- Halford, G.S.(1982). *The development of thought*. Hillsdale, NJ: Erlbaum.
- Hart, K. (Ed), (1981). *Children's Understanding of Mathematics: 11- 16*. London: John Murray
- Inhelder, B., & Piaget, J. (1958). *The growth of logical thinking from childhood to adolescence*. London: Routledge.
- Piaget, J. (1950). *The psychology of intelligence*. London: Routledge.
- Piaget, J. (1953). *The origin of intelligence in the child*. London: Routledge.
- Noelting, G. (1980). The development of proportional reasoning and the ratio concept. Part I— differentiation of stages. *Educational Studies in Mathematics*, II, 217-253.
- Rasch, G. (1980). *Probabilistic models for some intelligence and attainment tests*. London: University of Chicago Press.
- Shayer, M., Küchemann, D. E., & Wylam, H. (1976). The distribution of Piagetian stages of thinking in British middle and secondary school children . *British Journal of Educational Psychology*, 46, 164-173.
- Shayer, M., & Wylam, H. (1978). The distribution of Piagetian stages of thinking in British middle and secondary school children II: 14 -16 year-olds and sex differentials . *British Journal of Educational Psychology*, 48, 62-70.
- Shayer, M., & Adey, P. S. (1981). *Towards a Science of Science Teaching*. London: Heinemann Educational Books.
- Shayer, M., & Beasley, F. (1987). Does Instrumental Enrichment work? *British Educational Research Journal*, 13, 2, 101-119.
- Shayer, M., Demetriou, A., & Pervez, M.(1988). The structure and scaling of concrete operational thought: three studies in four countries. *Genetic, Social and General Psychological Monographs*,309-375
- Shayer, M. (1999). Cognitive acceleration through science education II: its effects and scope . *International Journal of Science Education*, 21, (8), 883-902.
- Shayer, M. (2003). Not just Piaget; not just Vygotsky, and certainly not Vygotsky as *alternative* to Piaget. *Learning and Instruction* 13, 465-485.
- Shayer, M. & Adhami, M.(2004). Realising the cognitive potential of children 5-7 with a mathematics focus. *International Journal of Educational Research* 39, 743-775.
- Smith, L. (2002). *Reasoning by Mathematical Induction in Children's Arithmetic*. Oxford: Elsevier Science.
- Spearman, C. (1927). *The abilities of man: their nature and measurement*. London: Macmillan.
- Tanner, J.M. (1978). *Foetus into Man: Physical growth from Conception to Maturity*. London: Open Books.
- Vygotsky, L.S. (1986) (Ed. A. Kozulin). *Thought and Language*. Cambridge, MA: MIT Press
- Wright, B.J. & Stone, M.H.(1979). *Best Test Design: Rasch Measurement*. Chicago: MESA Press.

ⁱ Published in *Educational Studies in Mathematics* 2007 pp 256-291